

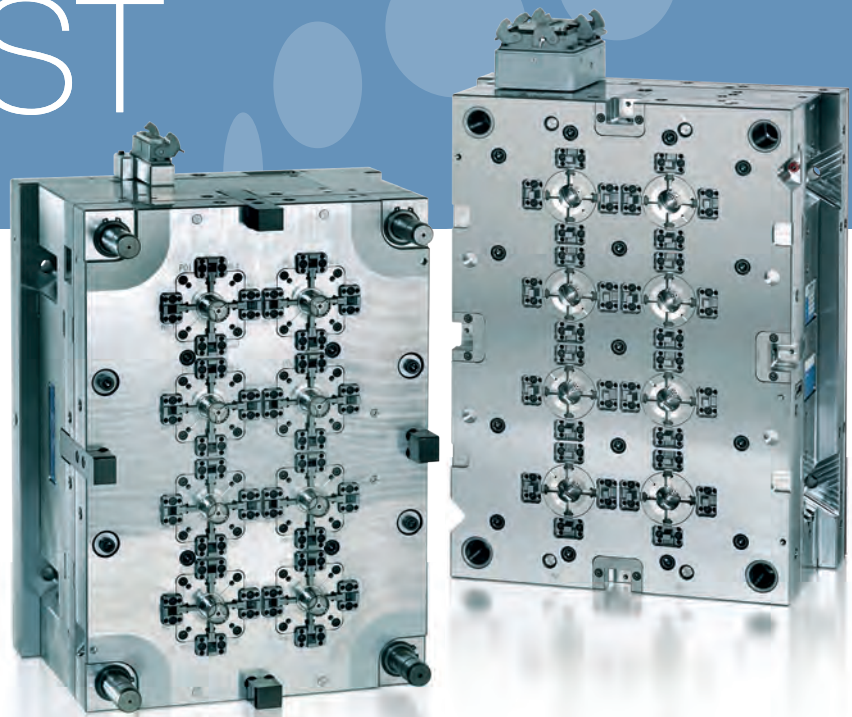

TOOLS TO TRUST

Injection molding
tools for the
medical industry



THE SMALLEST DETAIL MAKES THE GREATEST DIFFERENCE

“Precision relies on knowing what is important to our customers and their end-users. It is this knowledge that drives us to be specialists within tools for injection molding specifically for the medical industry.”

Kennet Filsø Madsen, CEO

At Sønderborg Værktøjsfabrik there is no such thing as almost precise. In our world a tool is either precise, or it is not. For more than three decades, our customers in the medical industry have trusted that the plastic parts in their products are of consistent, high quality, regardless of how many production lines are in operation; even when the molding tool is ejecting out part number one million. It is our goal to ensure that this happens.

The small things matter the most: Medical dosing equipment must deliver the exact dose of medicine every single time; a hearing aid must fit perfectly.

The users of insulin pens or other dosage systems need to know that their equipment is precise – their lives may even depend on it.

Quality through cooperation

More than 40 years of experience have given us a solid foundation for our services. Experience that we consider a crucial factor for helping you achieve your goals.

By participating in product development from kick-off, we contribute with valuable knowledge about tool design and injection molding. This means that you can be certain that you can achieve the quality and reliability your customers depend on.





With a technologically advanced and highly automated production facility, Sønderborg Værktøjsfabrik meets your expectations with regard to quality, reliability and durability. This is your guarantee for tools that achieve the highest quality standards.

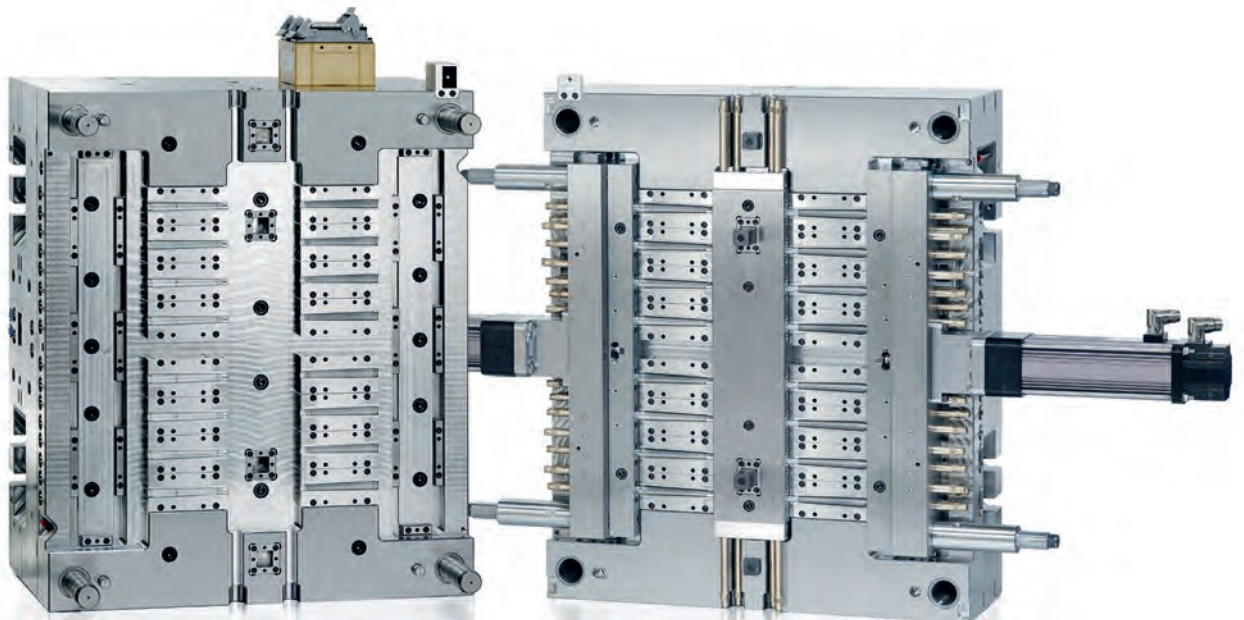

QUALITY TOOLS DEVELOPED BY SPECIALISTS

“Sønderborg Værktøjsfabrik develops and manufactures tools for injection molding for medical companies that demand the highest quality and output in their production.”
Niels Østergaard, Sales Manager

During the last four decades, we have built up an in-depth knowledge base about the demands for quality and cost efficiency in the medical industry.

Our more than 40 employees are all specialists within their respective fields, and are on the cutting edge of new developments within technologies, materials and processes. Constant competence development and training ensure that we always contribute with the newest knowledge when working on a project. Your benefit is that what we know becomes what you know.

By sharing knowledge we ensure that our cooperation matches the high quality of our solutions.

We only use the best equipment and materials in our production. A technologically advanced and highly automated facility, which is among the leading within our field, ensures the highest quality and longest life-time expectancy. In our view, this

is the only way we can achieve the precision and consistency that our solutions are known for.

We are the specialists

Sønderborg Værktøjsfabrik supplies tools for injection molding especially in the medical and hearing aid industries in Europe. Based on long term-relationships with our customers, we have cooperated with and supplied tools to the world's leading producers of, for example

- Medical dosing equipment, including pen systems and inhalers
- Hearing aids
- Laboratory equipment
- Pump systems
- Blood analysis



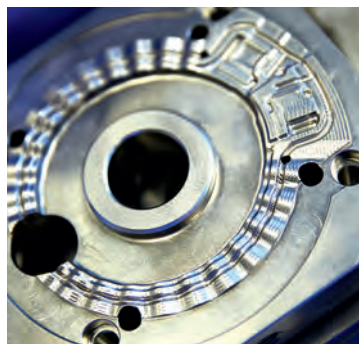
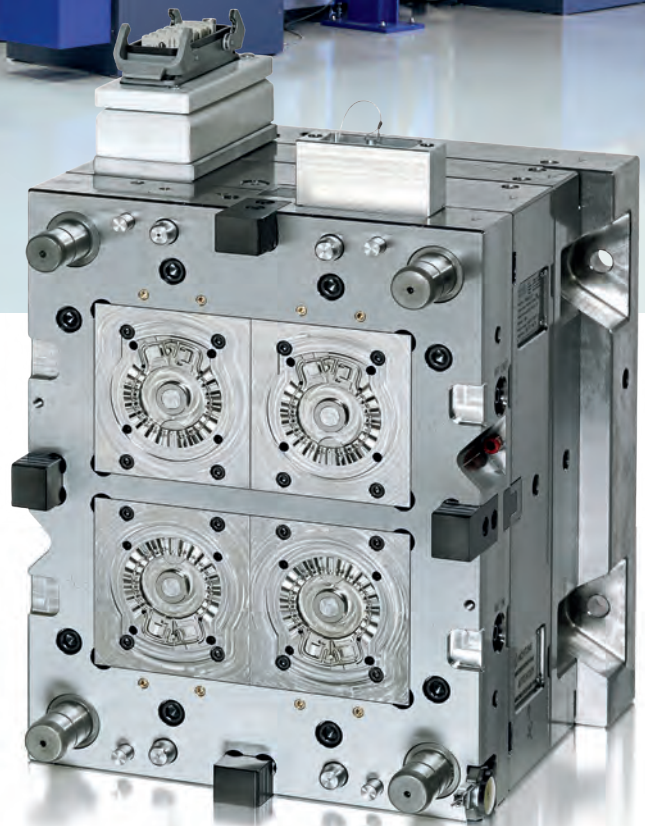

VALUE-ADDING PARTNER

“When you choose Sønderborg Værktøjsfabrik, you choose more than simply a supplier. We consider it one of our central tasks to be a value-adding partner, who builds the strong relationships that are so important if projects are to succeed 100%.”

Kennet Filso Madsen, CEO

Take advantage of our knowledge through-out the entire process: from idea generation, tool design drawings and production of prototypes, over testing and quality control to final delivery, test and maintenance of tools. We challenge assumptions intelligently and contribute to optimising products and processes that enable you to achieve your quality goals. All while keeping a sharp eye on reducing your project and production costs, and the risk of production delays.

Test and implementation

All tool parts undergo thorough quality control before they move to the next step in the production flow. This means that we can spot precision issues and other errors as early as possible and correct them accordingly.

When we have assembled the tool,

we run it through a live test in our testing facility. By testing the tool under real-life conditions, resembling the ones in your factory, we ensure that quality demands are met in the real world.

To achieve this we have injection molding machines that generate 50-175 tons of clamping force. This enables us to optimize the tool faster and more cost efficiently, compared to installing it in your production and making final adjustments there.

We can also install your own equipment and test the tool in the exact application it has been developed for. This is the ultimate test to ensure the tool functions perfectly.

Full discretion and complete documentation

All Sønderbog Værktøjsfabrik's customers are treated with full discretion and flexibility. Sensitive

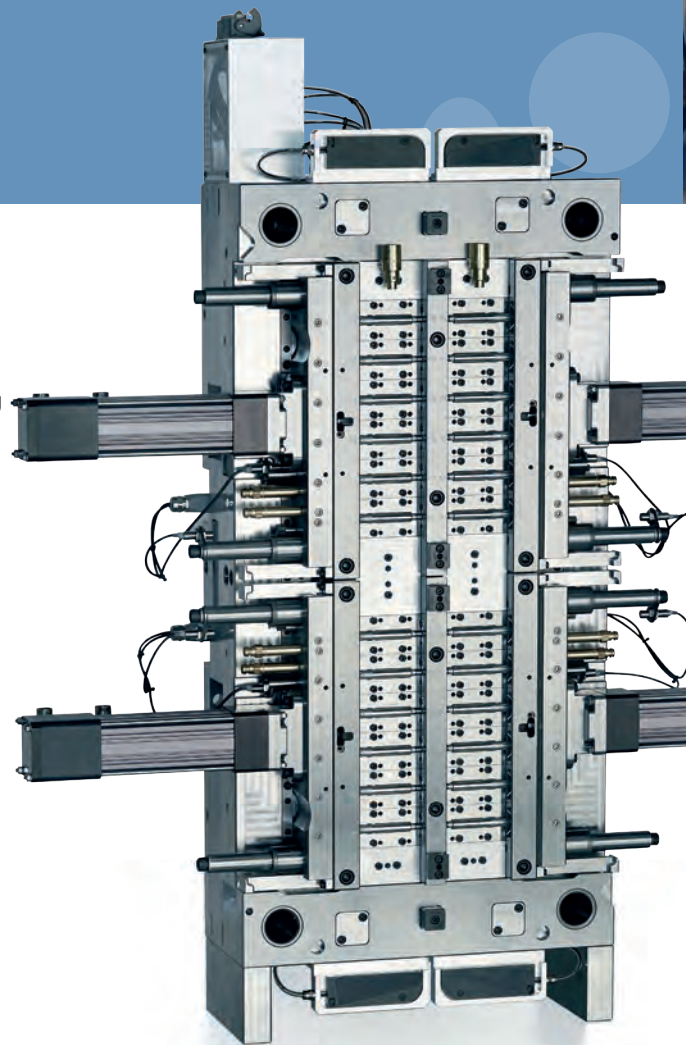

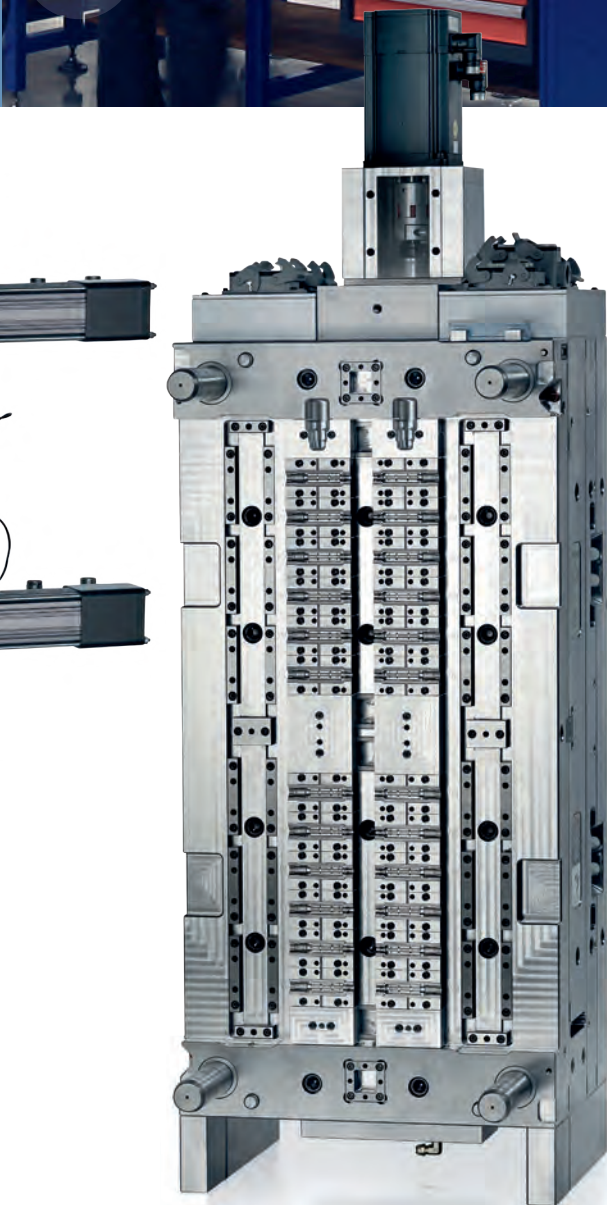
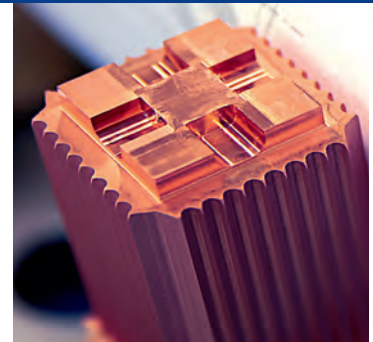

information, data and drawings are stored securely, and can only be accessed by ourselves and the individual customer.

As one of the only tool suppliers, we hand over tool design drawings and documentation in a complete package together with the tool. As a result, you can call on Sønderborg Værktøjsfabrik own service team, or use your preferred service partner, to handle repairs and maintenance on-site. This also provides an extra level of flexibility, helping you make costly production stops as short as possible.

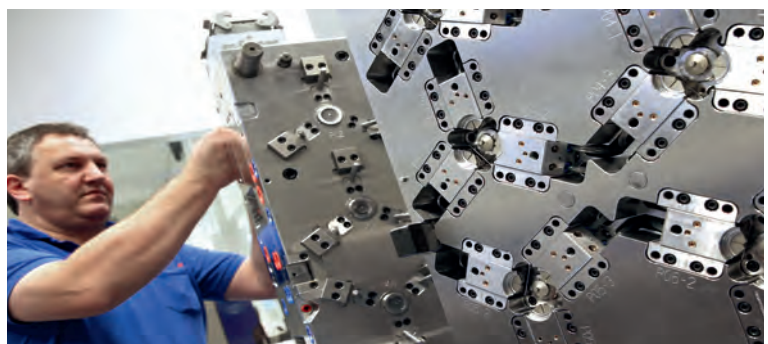

QUALITY DOWN TO THE TINIEST DETAIL



In the medical industry, quality of life may depend on only a few μ . The smallest details make the largest difference, and this is why Sønderborg Værktøjsfabrik has focused on what we do best for more than 40 years: quality tools for injection molding.

Our guiding principle is that our tools are only good enough when they are perfect. For example when they can mold 100 million parts or more without deviations.

More than 40 committed employees work towards the goal of delivering perfection. In close cooperation with our customers, we use the newest technologies, machines, tools and processes to ensure the highest quality, ultimate precision and extreme durability.

Sønderborg Værktøjsfabrik
TOOLS TO TRUST

Eiholm 6 · 6400 Sønderborg · Denmark · Tel +45 7442 8242 · sv@sv.dk · www.sv.dk